

VT49
NEL SOLCO DI UNA STORIA

1949
70°
2019
ANNIVERSARIO



TRC

HP 50 - 90 / KW 36 - 66

TRANCIA RACCOGLI SARMENTI / ERBA





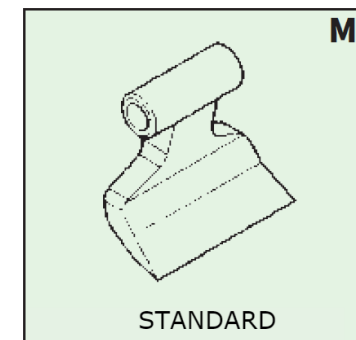
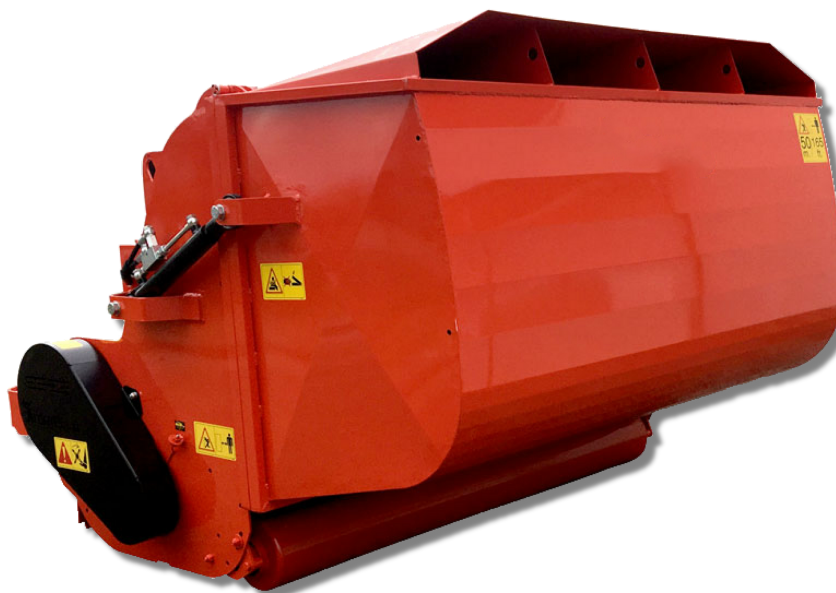

TRC

HP 50 - 90 / KW 36 - 66

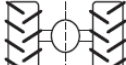

EQUIPAGGIAMENTO STANDARD

- Protezione antinfortunistica a norme CE
- Giunto cardanico
- Ruota libera a bagno d'olio nella scatola
- Rullo posteriore autopulente
- Martelli lisci
- Contro-piastra martelli smontabile
- Piedino di appoggio
- Doppia fila di bandiere di protezione anteriori
- Convogliatore anteriore per sarmenti
- Cassa di raccolta con apertura a mezzo martinetti idraulici
- Porta d'ispezione ai martelli
- Presa di forza 540 g /m

MODELLO	 cm	 cm	 cm	 HP KW	 .N	 .Kg
TRC-200	220	200	100__100	65-90	18	801
TRC-180	200	180	90__90	60-90	16	770
TRC-160	180	160	80__80	60-90	14	733
TRC-140	160	140	70__70	50-90	12	690

RICHIESTE - OPTIONAL

- Barra luci posteriore per trasporto su strada